



EUCASTREAM



EUFOR

EUFOR INTER

S.P.R.L. EUFOR INTER B.V.B.A.
Eupen - Liège - Antwerpen

Head offices
Am Hertogenwald, 7
B-4700 Eupen
Belgium

Tél. +(32) 87-63.23.00
Fax +(32) 87-63.23.01

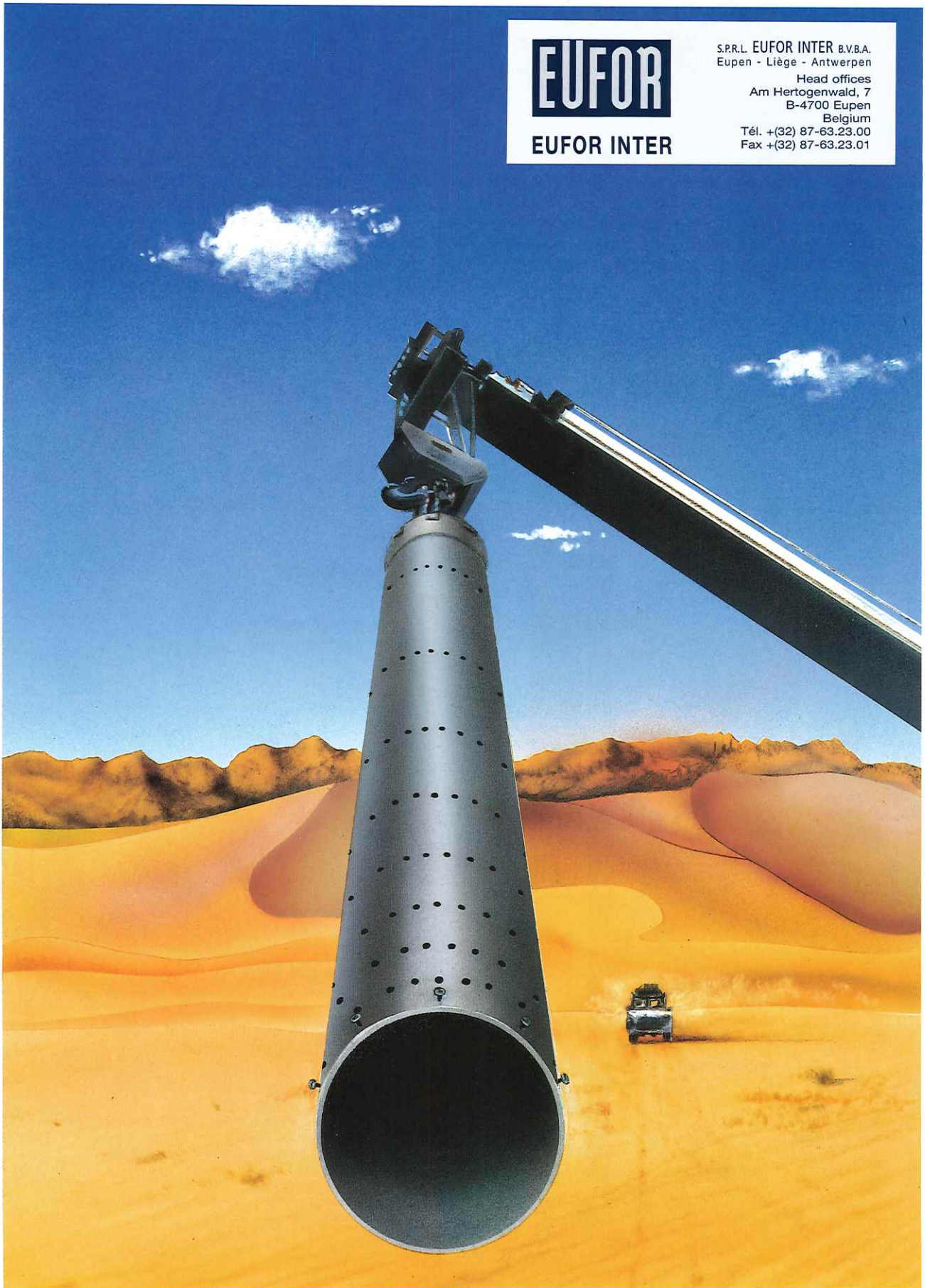

Eucastream - Suction Flow Control Device (SFCD)

the novel system for the improvement of flow conditions in wells :

- water delivery free of sand and turbidity
- retardation of biofouling processes
- increase of working life of wells
- utilization of total filtering zone (screen length), i.e. increase of well performance
- lower maintenance costs
- prevention of pump wear due to elimination of sand pumping

1. WELL WITHOUT SFCD

In compliance with fig.1 an ideal conventionally constructed well has a well screen of the length L corresponding with the thickness of the water-bearing layer, and above the well screen a casing in the range of the impermeable layer. The annular space between borehole and well screen resp. casing is filled with gravel. The submersible pump is positioned in the casing.



EUCASTREAM

registered trade mark of Kabelwerk Eupen AG, B-4700 Eupen

Prof. Kirschmer, Darmstadt, W.-Germany, made a sucking test with a well screen, which was vertically positioned in a water-filled basin concentrically to its center-line. This test arrangement was intended to simulate a water collecting «free» well screen, that means a well screen installed in a borehole and not surrounded by a gravel pack. The water is collected by this «free» well screen corresponding with the

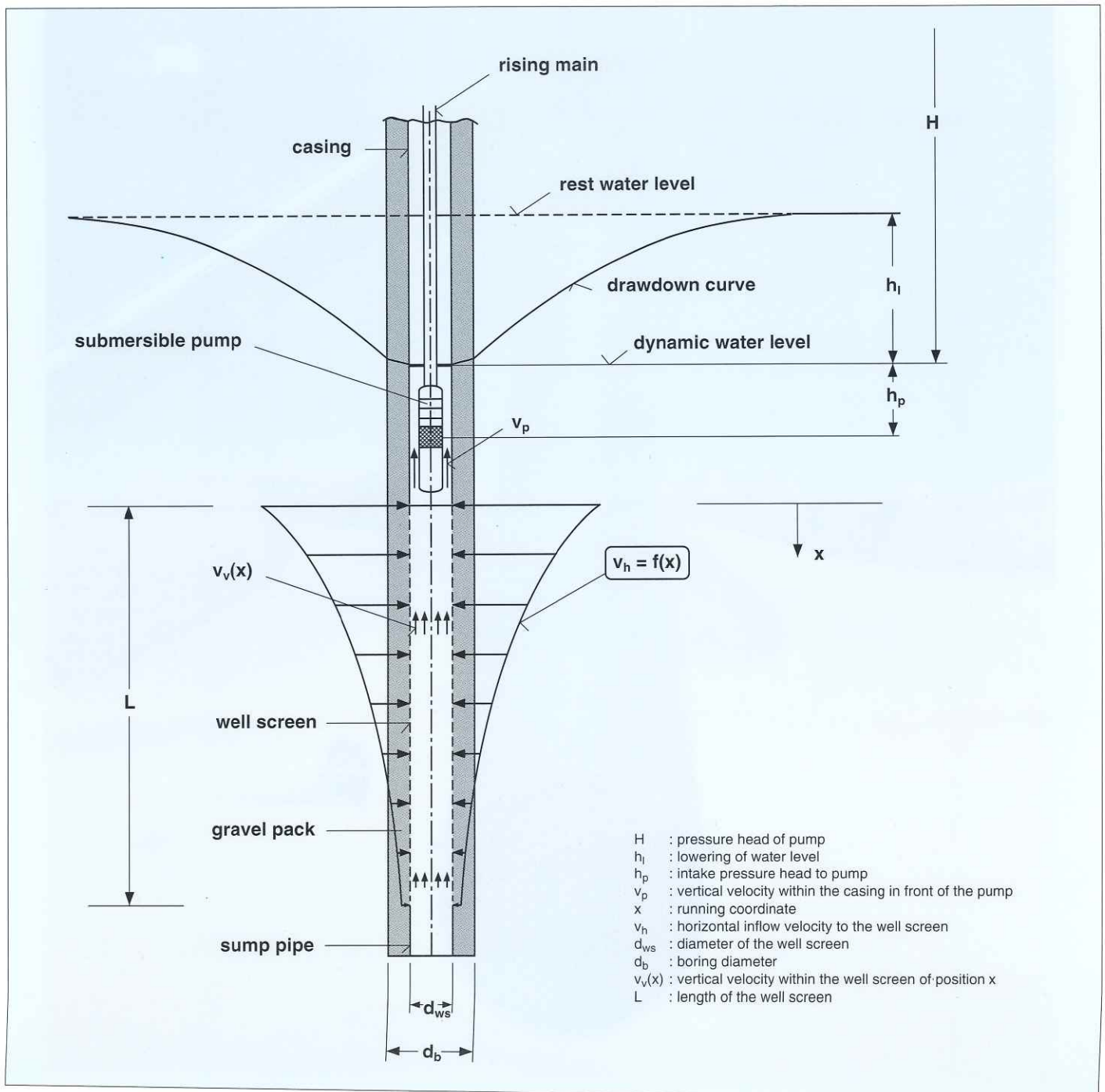

Fig. 1 : water flow in a conventional bore well

diagram in fig. 2: The inflow velocity $v_h(x)$ has its maximum at the upper end ($x=0$) and decreases rapidly downwards. At the point $x=l$ is $v_h=0$ and the remaining length $L-l$ is practically not passed by water flowing in.

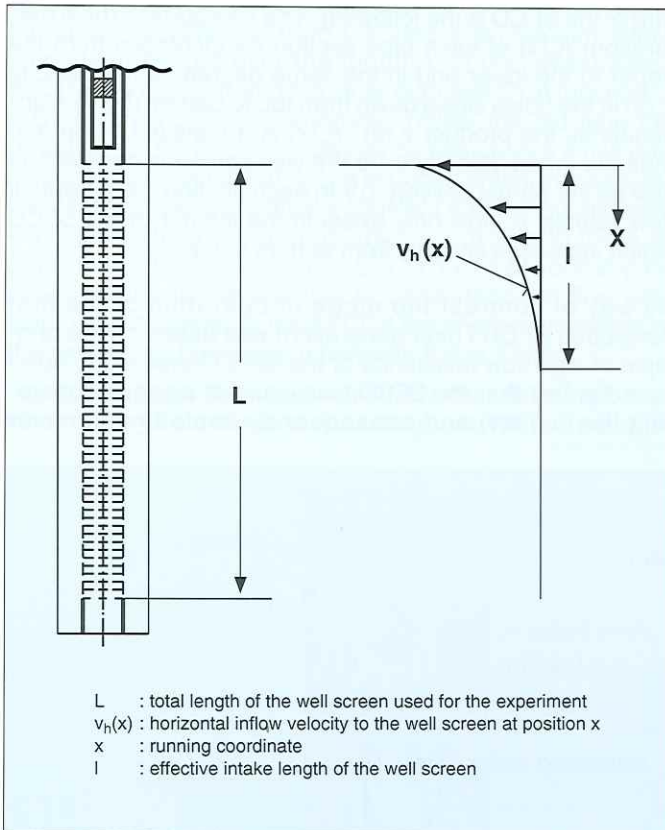

Fig. 2 : inflow to a “free” well screen

A very similar collecting characteristic $v_h(x)$ is shown by the well screen in a conventionally constructed well according to fig. 1: As it was demonstrated by theoretical and experimental investigations, $v_h(x)$ decreases exponentially from the upper to the lower end. Entering the gravel pack the water flow is deviated in a more or less upward direction (in certain stages of the entering length nearly vertical upward flow) and near the wall of the borehole there arise upward components of the velocity here and there coming up to a multiple of the flow velocity of the water at the exit of the aquifer. This process of flow is demonstrated by fig. 3.

For simplifying reasons $v_h(x)$ is supposed to decrease to zero in linear manner from the upper part ($x=0$) to the lower part ($x=L$). For reasons of representation the horizontal measurements are drawn in a greater scale than the vertical ones. The length L is divided into 10 sections Δx of 10% of L . Merely 1% of the water flowing in from the aquifer is allotted to the lowest 10% of L , and in compliance with the continuity equation 19% of the water coming in from the aquifer are flowing through the highest 10% of L into the well screen. This is the reason for diverging flow lines in the lower part and converging lines in the upper part of the gravel pack, and the steepest flow lines are significant for the greatest upward components of the velocity at the wall of the borehole. The fact that the water is flowing through the gravel pack in the above demonstrated manner can be proved by the calculation of the pressure losses of the gravel pack,

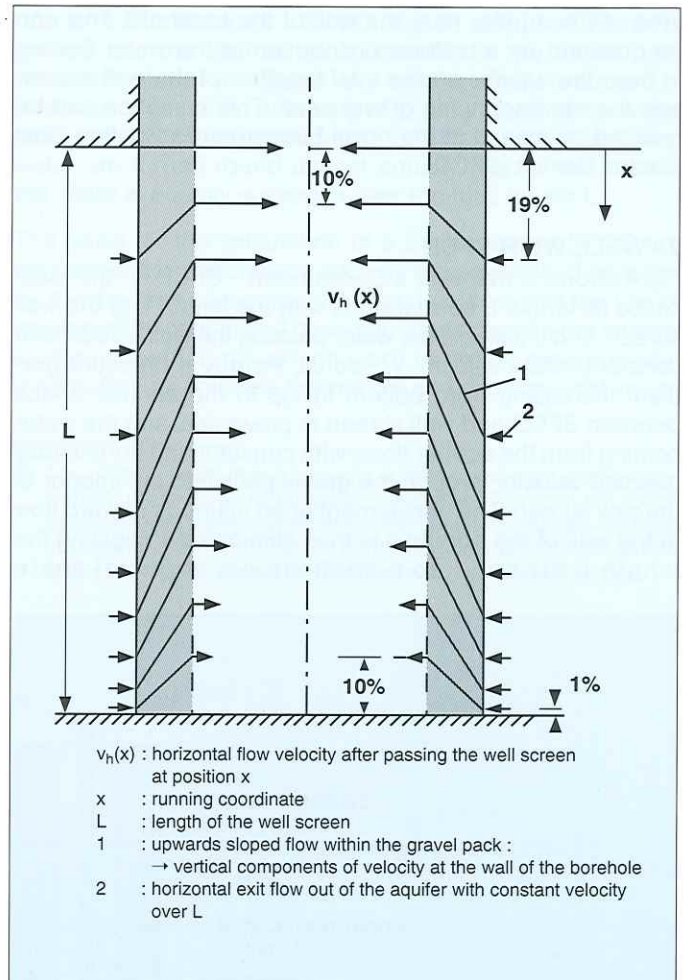

Fig. 3 : flow through the gravel pack of a conventional well (without SFCD)

of the slots of the well screen - in both cases horizontal direction of water flow \rightarrow , and of the interior of the well screen - vertical flow direction \uparrow . For an example similar to practice these pressure losses would be in the ratio of 0,013 to 0,044 to 1. That means: the pressure loss in the gravel pack is sloping upwards (horizontal-vertical direction) being guided along by the vertical pressure drop within the well screen.

With the help of these considerations the following defects of a conventionally constructed well can be revealed:

- excavation of sand from the wall of the borehole with consequential damages
- sand in the pumped water
- wear of the pump and subsequent armatures
- local breakdown of the borehole wall
- subsiding of the gravel pack
- clogging of the gravel pack due to silt deposits and bio-fouling precipitation causing diminished pumping capacity.

In summary these facts lead to a premature aging of the well, in some cases the wells have even been useless from the beginning. The well sinker has often been charged with these drawbacks, in most cases he was wrongly blamed, because the damages are caused by flow-mechanical effects. Consequently an optimum well should meet the following demand: Prevention of upward-directed flow within the gravel pack and - in case of good permeability - in the

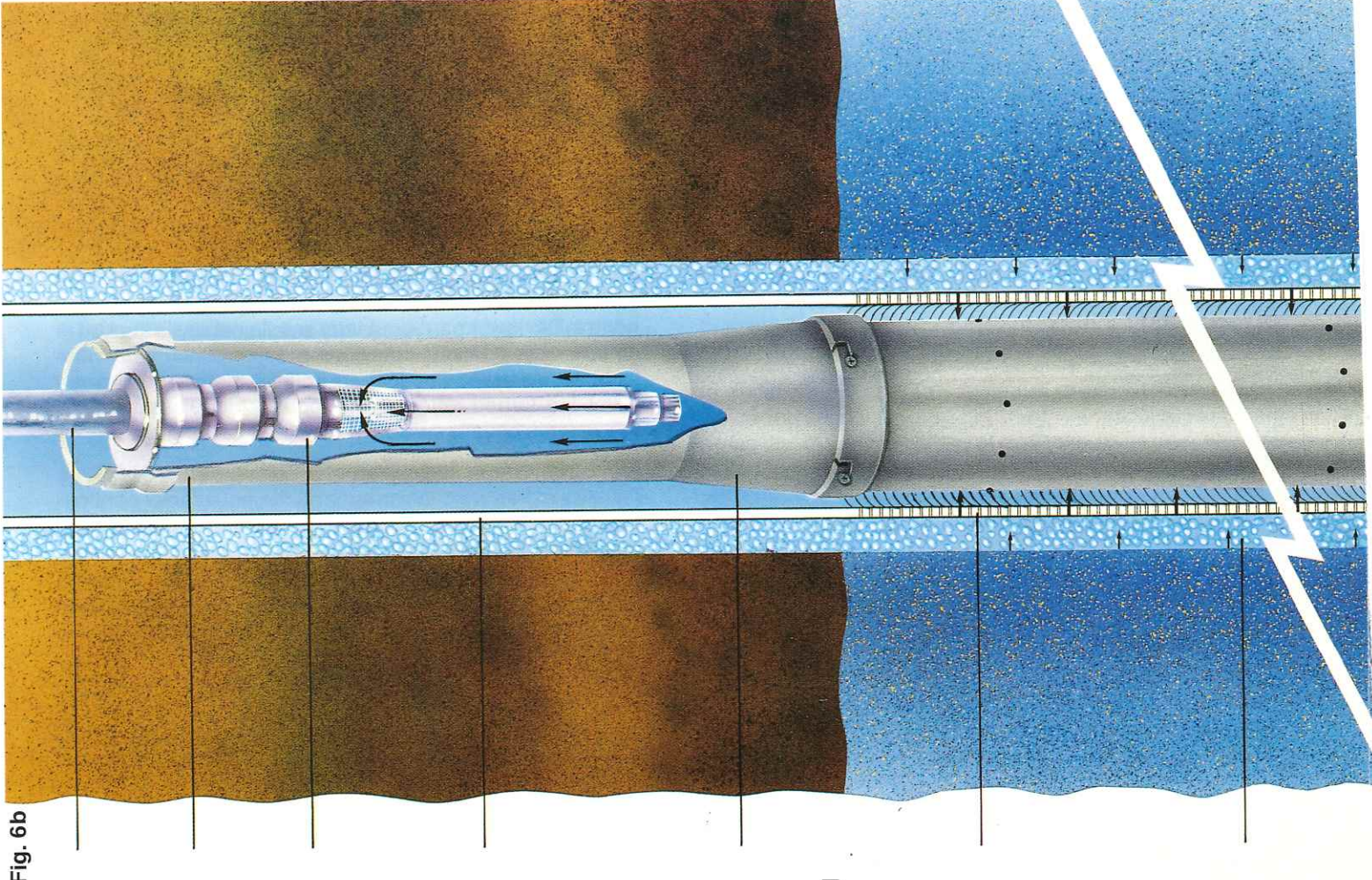
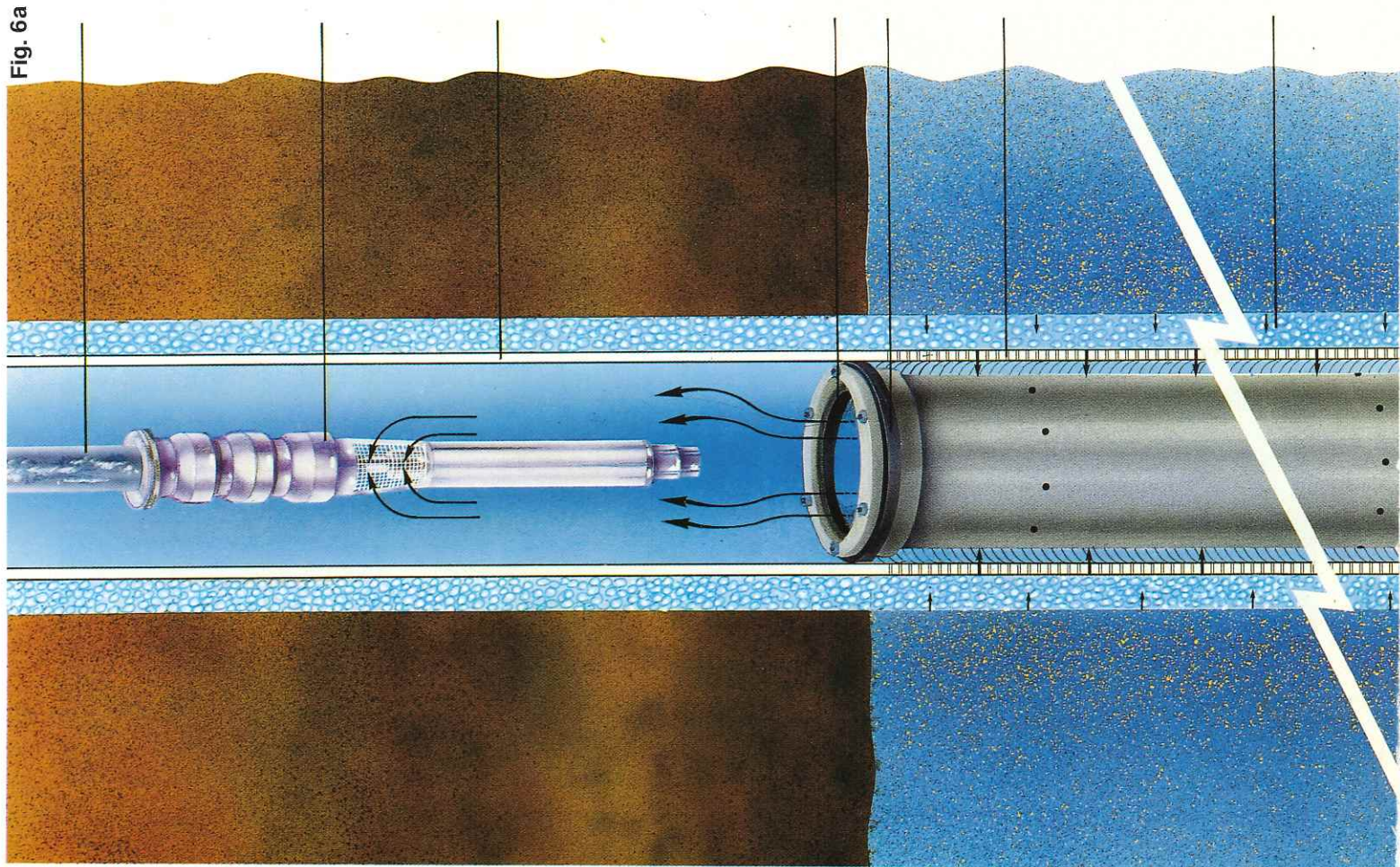

- rising main
- pump jacket
- submersible pump
- casing
- adapter
- PVC-lifting ring
- sealing unit
- screen
- gravel pack

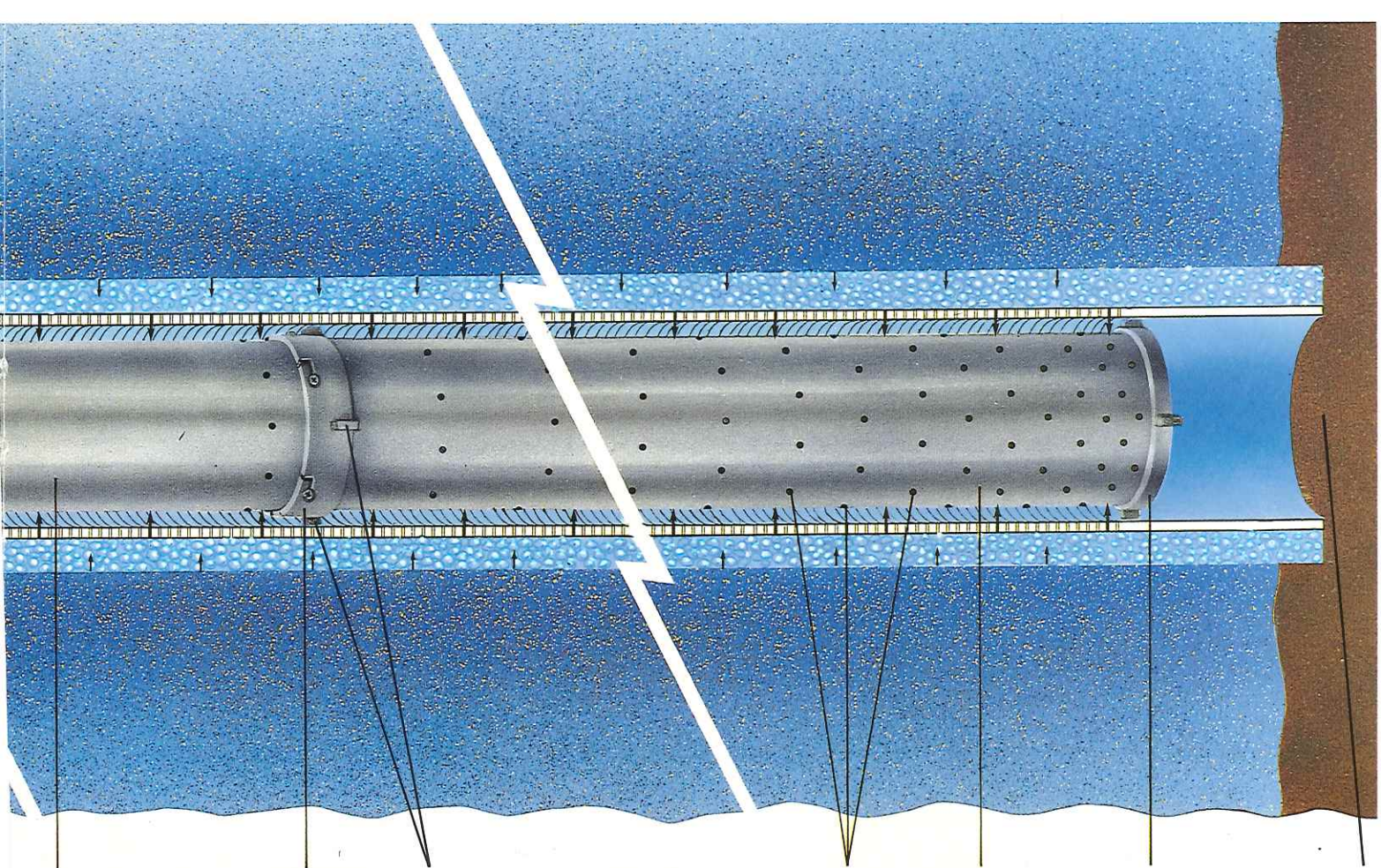

SFCD-controlling pipe element

plain socket stuck on with bayonet locks

centralizers

differentiated hole pattern

lowest SFCD-controlling pipe element

bottom cap stuck on

socle

bottom cap well bottom

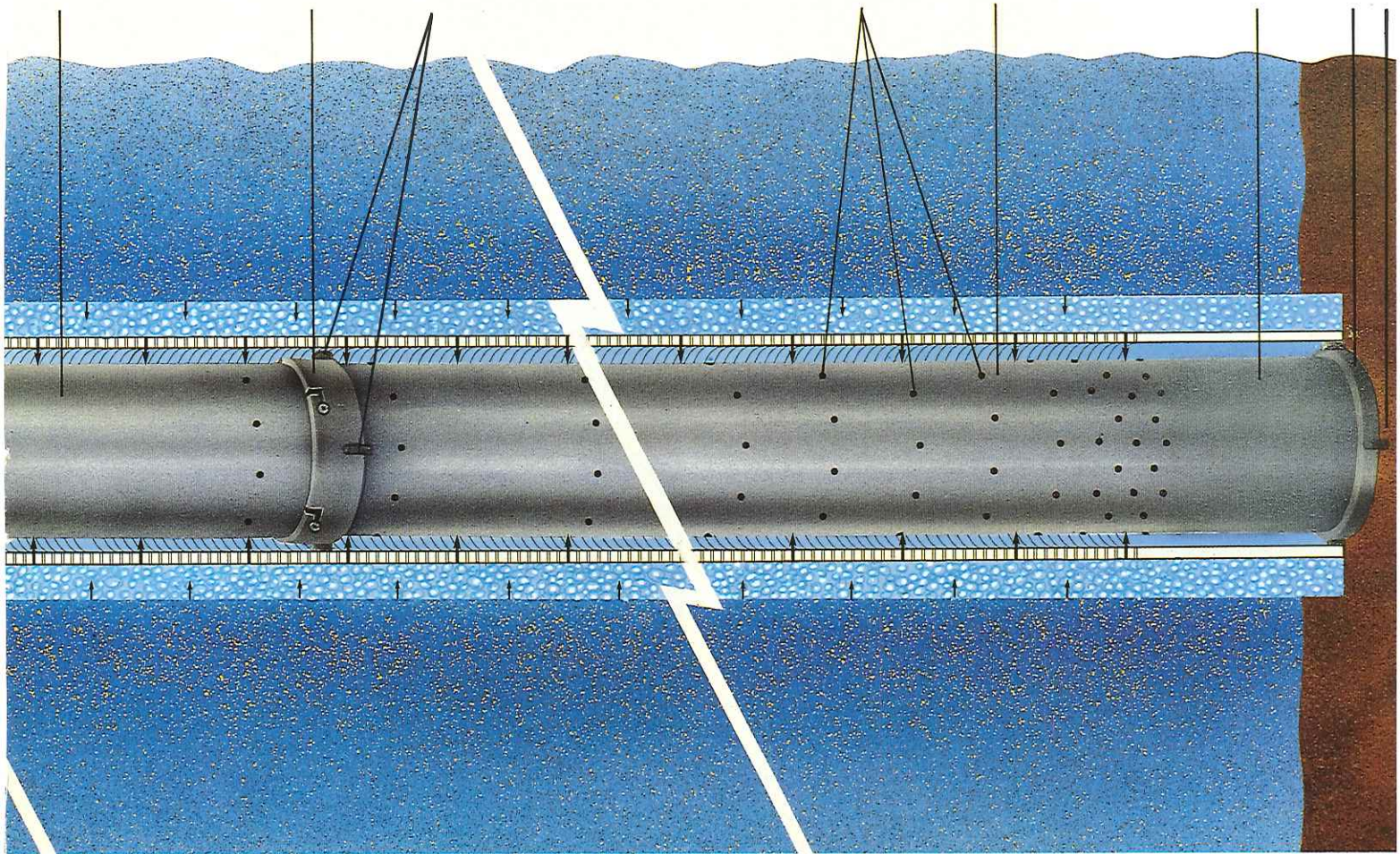

SFCD-controlling pipe element

plain socket stuck on with bayonet locks

centralizers

differentiated hole pattern

lowest SFCD-controlling pipe element

bottom cap stuck on

socle

bottom cap well bottom

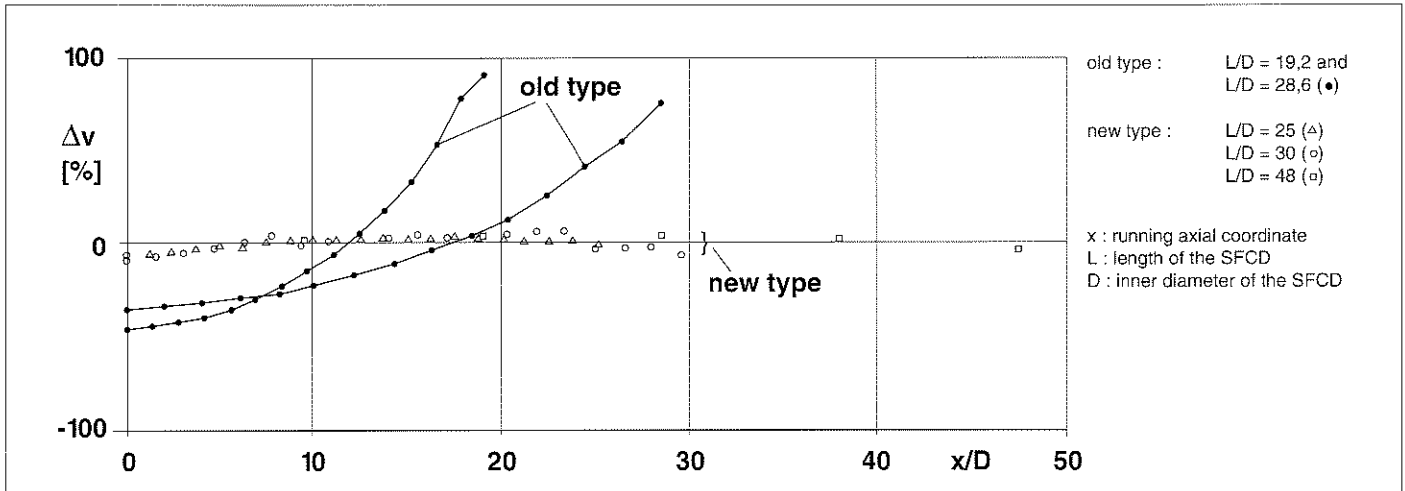

Fig. 7 : deviation Δv from the zero-line in function of x/D for the SFCD I (old type) and SFCD II (new type)

tigations a computer program was developed for the calculation of the free surface $A_p(x)$. SFCD designed according to this program reduced sand-conveying and -pumping of wells in stationary operation for more than 99% of the initial values, though the aquifers were not homogeneous and the length of the SFCD and water-bearing layers did not correspond.

3. CONSTRUCTION OF THE EUCASTREAM - SFCD

Two SFCD-variants with regard to the mode of installation in a well are applicable: the standard- and the pump jacket - SFCD. The former (fig. 6a), simply constructed and low-priced, can be applied under normal conditions. It is not coupled with the pump - submersible or shaft pump -, i.e. it can be installed independently of it. This SFCD consists of the variably perforated control pipe elements, the socle pipe at the lower end and the sealing unit at the upper end. The pipe elements are connected by formlocking bayonet joints in plain sockets, the lower half of which is in each case stuck on the upper end of a pipe element. Self-tapping Parker-screws of stainless steel engage into L-shaped oblong holes. The socle, usually a plain pipe as long as the sump pipe, is set up on the bottom of the well, i.e. the whole

SFCD rests on the bottom. At the upper end of the SFCD the annular space surrounding it is sealed up against the interior of the casing above by a sealing which consists of a 20mm-thick closed-porous Neoprene foam-flat ring. This ring is, with view to its outer diameter, slightly overdimensioned in relation to the inner diameter of the casing. As a result the water of the aquifer sucked in is forced to flow into the interior of the SFCD and within the device vertically upwards. By means of a specially constructed gripping device with spreading arms engaging under the lifting ring stuck inside the wall of the topmost plain pipe element of the SFCD and a steel rope the latter is moved down to its operating position in the well. After disengaging the spreading arms the gripping device is pulled out. If necessary the SFCD can later be lifted up in the same way. After its installation the pump is suspended into the casing in the well-known conventional manner.

The SFCD with pump jacket (fig. 6b) is identical in its perforated part with the standard-SFCD but unlike to that it is coupled with the submersible pump by a pump jacket (specially constructed plain pipe), i.e. it has to be installed together with the pump and so is likewise suspended freely

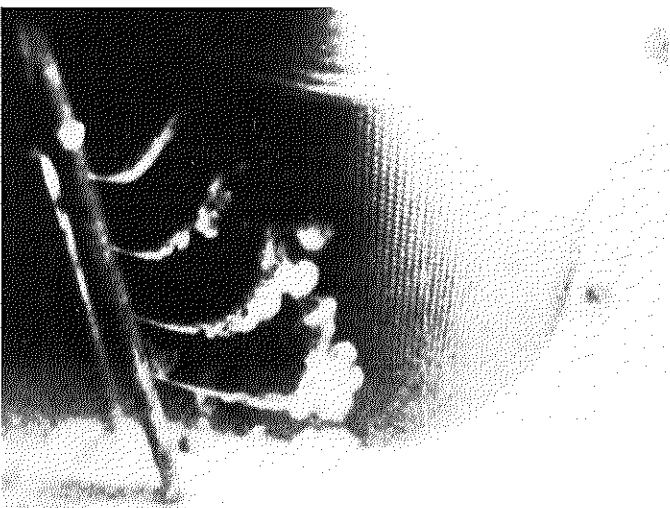

Fig. 8 : Simulating inflow test only with a well screen: coloured water filaments are *unequally* sucked in over L.

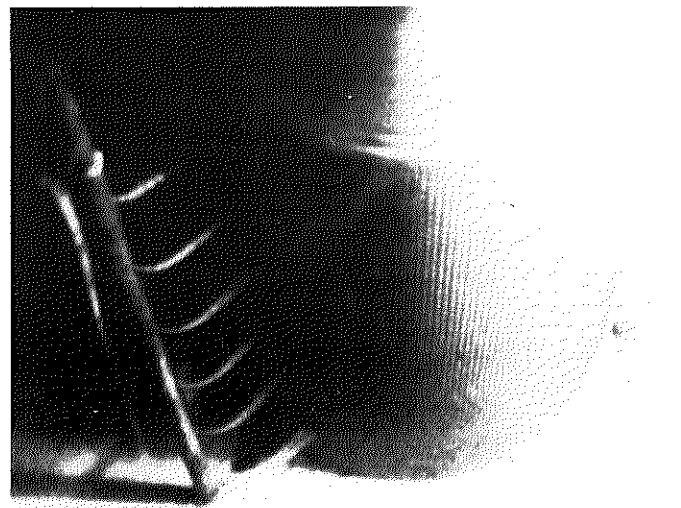

Fig. 9 : Simulating inflow test with a well screen *and* a SFCD: coloured water filaments are *equally* sucked in over L.

from the rising main (supporting socle is not necessary). The pump enclosed like this can only suck in the water via the control pipe elements and the pump jacket. If a shaft pump is applied the SFCD can be coupled directly to its sucking end by means of a special socket adaptor. - This suspended SFCD-variant should be applied either if a good sealing by the Neoprene foam-flat ring cannot be guaranteed (e.g. wells without casing), or if a stronger aggradation of the well sump must be expected, e.g. due to the biofouling processes (standard-SFCD would not be applicable in such cases because the socle would be retained by the biofouling slime and thus a later lifting up of the SFCD would become impossible).

4. DIFFERENT SFCD - DESIGN CONCEPTIONS

The design of a classical vertical well normally shows one continuous screen section in the area of the water-bearing stratum and a casing section above. The pump is positioned above the screen in the casing and the dynamic water level has adjusted itself distinctly above the pump (fig. 1). In order to avoid sand-conveying the lowering funnel in wells with unconfined aquifers should not reach into the screen section, i.e. the dynamic water level should always be located in the casing area. The SFCD should be designed - as mentioned already before - as long as the screen section, the length of which normally corresponds with the thickness of the water-bearing stratum. If there are several water-bearing strata of considerable thickness with impermeable intermediate formation layers, the screen is interrupted in these segments by intermediate casing sections (thin impermeable layers are integrated in the screen sections). Correspondingly the SFCD is constructed with intermediate sections of plain pipes in these sections, too. For this «interrupted» SFCD as well a computer program was developed in order to calculate the differentiated perforation of the control pipe elements in those screen areas. Furthermore it is often necessary to position the submersible pump in the sump pipe or within the screen area - in the latter case surrounded by an adequately long plain pipe section of the SFCD, of course - when the dynamic water level is reaching up to or even into the screen. Also these operating conditions can be met by an adequate design and calculation of the SFCD.

5. THE POSITIVE EFFECT OF THE EUCASTREAM - SFCD

Present experiences have clearly shown that the flow conditions in most differently constructed wells are essentially improved by the installation of adequately designed and calculated SFCD.

5.1. Sucking in and pumping of sandfree water

5.1.1. Rehabilitation of sand-conveying wells

The effectiveness of SFCD with regard to sand-conveying is clearly demonstrated by two typical case histories from the more and more increasing number of successful SFCD-applications:

Example 1 (Netherlands, $\dot{V} = 33 \text{ l/s} \approx 523 \text{ gpm}$): Sand pumping at steady operation without application of SFCD:

c. 20 ml/m^3 ; sand pumping at steady operation (even two hours after beginning of pumping) with application of SFCD: c. $0,5 \text{ ml/m}^3$;

Example 2 (Bavaria, $\dot{V} = 70 \text{ l/s} \approx 1100 \text{ gpm}$): Sand pumping at steady operation without application of SFCD: c. 100 ml/m^3 ; sand pumping at steady operation (even one hour after beginning of pumping) with application of SFCD: c. 1 ml/m^3 .

In both cases there was not any sand detected after several hours of steady operation. The result of example 2 must be looked upon as astonishingly good because for technical reasons the SFCD could be designed only half as long as the screen section of the well. The application of SFCD in sand-conveying old wells, which are already in operation for some time, leads to their rehabilitation and results in the following positive effects:

- separation of sand from the pumped water is not necessary;
- no further wear of the pump and the subsequent armatures;
- no further forming of caverns in the aquifer in the area adjacent to the wall of the borehole, consequently no subsiding of the gravel pack which means life maintenance of the well.

5.1.2. Preventive protection for new wells

The successful rehabilitation of old wells by means of the SFCD should, however, logically initiate the preventive installation of SFCD in new wells. The hydrodynamical considerations conducted at the beginning of this brochure demonstrated that even carefully constructed conventional new wells are not proof against sand-conveying in the course of their operating life lasting perhaps for decades (concealed slow flushing out of caverns). The most certain preventive effect of the SFCD is obtained when it is already integrated in the design of a new well. With view to sand-conveying this is the only guarantee to preserve the initial state of the well in the long run.

5.2. Sucking in and pumping of clear water free of turbidity

There are a lot of wells conveying turbid water. The particles causing turbidity are so fine that they do not settle out in a gauge glass under the effect of gravity. In conventional wells the water sucked in flows vertically upwards in the gravel pack with relatively high velocity. As a consequence these ultra-fine particles are washed out of the wall of the borehole sunk into a correspondingly conditioned formation layer and are pumped up.

Example 1 (Sindel-Langenthal, Germany): 115 m deep well, sunk into five water-bearing strata of sandstone with clefts, fissures and gaps, separated by impermeable intermediate layers of sandstone with strong deposits of clay and lime; pumped water at $\dot{V} = 18 \text{ m}^3/\text{h} \approx 79 \text{ gpm}$ milky-turbid; after installation of the 80 m long SFCD with adequately adjusted sections of perforated and plain pipes, the pumped water at $\dot{V}_{\text{max}} = 36 \text{ m}^3 \approx 158 \text{ gpm}$ is absolutely clear.

Example 2 (Trendelburg, Germany): 147 m deep well, sunk into two water-bearing strata of sand- and siltstone with clefts, gaps and fissures, separated by an impermeable intermediate layer of siltstone; pumped water at $\dot{V}_{\text{max}} = 80 \text{ m}^3/\text{h} \approx 352 \text{ gpm}$ turbid of grey-brown colour; after

installation of about 55 m long SFCD with adequately adjusted sections of perforated and plain pipes, the pumped water at $\dot{V}_{\max} = 80 \text{ m}^3/\text{h} \approx 352 \text{ gpm}$ is absolutely clear.

Example 3 (Albisheim, Germany): 250 m deep well, sunk into two water-bearing strata of new red sandstone with clefs, gaps and fissures, separated by an impermeable stratum of homogeneous fine-grained new red sandstone; pumped water $\dot{V} = 20 \text{ m}^3/\text{h} \approx 88 \text{ gpm}$ extremely turbid of intensive red-brown colour; after installation of the about 130 m long SFCD with adequately adjusted sections of perforated and plain pipes the pumped water at $\dot{V}_{\max} = 40 \text{ m}^3/\text{h} \approx 176 \text{ gpm}$ is absolutely clear.

5.3. Rehabilitation of incrustations due to biofouling

According to experiences incrustation due to iron and manganese biofouling preferably takes place in those areas of the well where bacteria, the excretions of which form the biofouling slime (precipitation), are supplied with the greatest amount of food (metal ions dissolved in water). Logically these conditions are given in conventional wells in the upper part of the well screen and in the vast upper and middle part of the gravel pack due to the fact that in these areas horizontal respectively vertical flow velocities come up to the highest amounts as shown in chapter 1. The result is an accelerated biofouling process in these areas and consequently the upper screen slots and the flow paths in those mentioned vast parts of the gravel pack will clog first by the ochre slime of the bacteria. Inevitably the inflow is dislocated further downwards as the clogging process of the gravel pack proceeds downwards, too. The flow of the water from the aquifer into the well is more and more diminished because the inflow range is increasingly narrowing (throttling effect). At the same time a steady lowering of the dynamic water level takes place until finally the pump is in pressing danger of dry operation. Now at the latest the well has to be shut down and an expensive rehabilitation becomes necessary.

Two serious drawbacks are caused by the increasing reduction of the inflow area:

- In the steadily reduced intake area the velocity of the water sucked in increases more and more until finally the high velocities lead to sand-conveying of the well.
- The permanent lowering of the dynamic water level leads to an increasing pumping head and consequently to higher costs of energy.

The installation of SFCD in wells with imminent danger of incrustation effects a uniform and horizontally directed flow of water sucked in from the aquifer along the total screen length. Consequently all flow peaks are eliminated and the equalized velocities of influx kept on a low level. Thus the intended slowing and dispersing of the clogging process all over the total filtering zone (screen with surrounding gravel pack) is enabled and the working period of the well between two rehabilitations is considerably prolonged. The consequences are not only reduced costs of rehabilitation arising during the total working life of the well, but also elimination of sand-conveying and diminished energy costs of the pump.

5.4. Influence on the lowering of the dynamic water level

The power consumption of a pump depends on the flow rate (delivery) and the head of the water to be pumped. The latter on its turn is in a high degree defined by the lowering of the ground water level. The chief cause for the lowering of the ground water level (drawdown), however, is the pressure loss of the flowing water in the pores of the aquifer. The flow through the screen slots as well as through the holes of the SFCD practically occurs without pressure loss. Considerably higher on the other hand is the pressure loss of the vertical flow within the screen and in the gravel pack. If an SFCD is applied now this vertical flow exclusively occurs in the interior of the device. The diameter of the SFCD is in any case a bit smaller than that of the screen, consequently the vertical flow velocity in the SFCD and the corresponding pressure loss must be somewhat higher than in the screen. On the other hand the pressure loss of the vertical flow in the gravel pack of conventional wells is not likely to be negligible, as the flow is much «rougher» here than in the smoothbore pipes of the SFCD. In short the pressure losses in both systems (well without, well with SFCD) are likely to be identical, neither positive nor negative influence of the SFCD on the drawdown can be detected. This statement correlates well with the present experiences.

6. Final remarks

The Eucastream - SFCD, a totally corrosion-resistant, hygienically and toxicologically unobjectionable system, should preferably be installed in new wells endangered by sand-conveying, water-turbidity and biofouling incrustation. References make obvious that the SFCD can also be successfully applied in old wells damaged by any of the a.m. phenomena. Those cases, however, request a careful investigation of well construction and conditions in order to guarantee the success eventually with the help of accompanying rehabilitation measures. The SFCD are individually designed for each well and are constructed according to the well data, beforehand recorded by the customer in the prepared questionnaire with sketch. Eucastream - SFCD can be produced in any length, with any requested diameter of the pipe, for any well design and any desired flow rate. They are normally manufactured of uPVC - pipes suited for drinking water. For extraordinary deep wells or for those delivering hot water (e.g. in the Near East) the SFCD are manufactured of thin-walled pipes of stainless steel.

Well designers and drillers should not neglect an interesting economic aspect: the application of a Eucastream - SFCD allows to drill much smaller boreholes for new wells and consequently to use casings and screens considerably smaller in diameter as well as much smaller quantities of gravel for a package of the same thickness. Such a «lean» well, though with view to hydraulics and economy operating as effective as a conventional well - careful desanding presupposed - should be constructed by far cheaper than the latter. Equipment and know-how for the installation of Eucastream - SFCD are not different from those necessary for mounting a submersible pump. Fig. 10, 11, 12, 13 show several assembly stages during the installation of SFCD in sandconveying wells.



Fig. 10: Mounting of an SFCD-plain pipe element.



Fig. 11: Mounting of an SFCD-controlling pipe element.

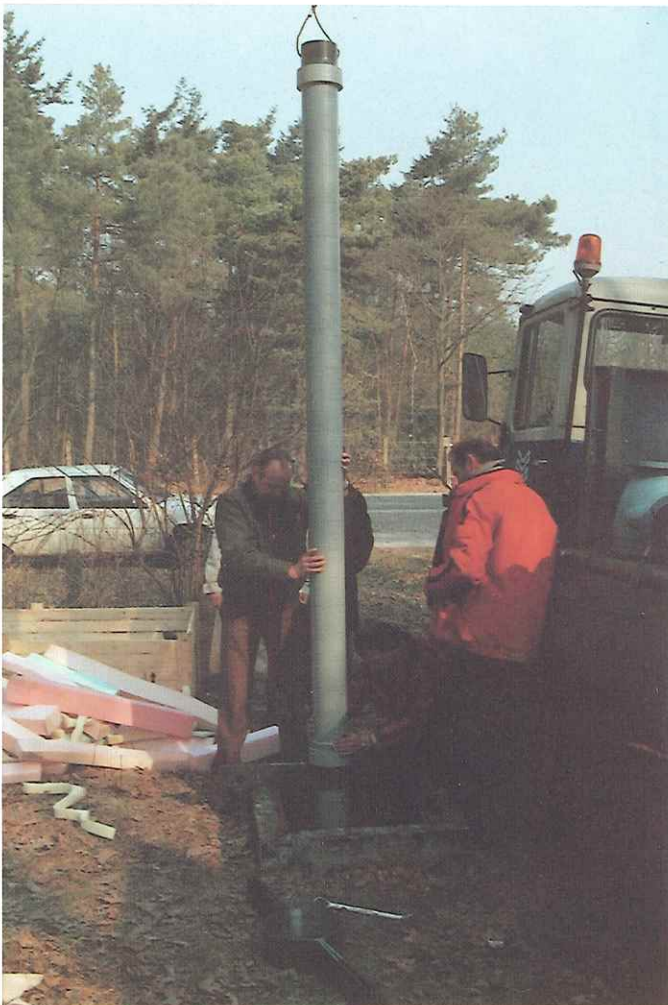

Fig. 12: Mounting of the highest control element on the lower elements already moved down into the borehole.



Fig. 13: Installation of the submersible pump into the pump jacket already moved down into the borehole.

KABELWERK AG

B 4700 EUPEN



CABLERIE D'EUPEN s. A.

All statements as to the properties or utilization of the products mentioned in the following papers refer to our latest experiences and are only for the purposes of description. Guarantees in respect of the existence or certain properties or utilization of the products mentioned are only valid if agreed upon in writing.



The Plastic Pipe Division of the Kabelwerk Eupen runs one of Belgium's most important extrusion and injection moulding plants. Its manufacturing program covers PVC-, CPVC-, PE- and PP-pipes and -fittings for almost any application, e.g.

- pressure pipe systems conveying hot and cold liquids for: chemical and food industry, gas and water supply, sanitary installations, radiator and floor heating,
- pressureless pipes for electrical cable ducts, sewage and discharge,
- special pipe system as protection duct for optical fiber cables.

EUFOR
EUFOR INTER

S.P.R.L. EUFOR INTER B.V.B.A.
Eupen - Liège - Antwerpen
Head offices
Am Hertogenwald, 7
B-4700 Eupen
Belgium
Tél. +(32) 87-63.23.00
Fax +(32) 87-63.23.01

☎ 00 32 87/55.47.71
14 L.

TELEX
49-218

TELEFAX
087/74.32.09

PSK - CCP - PCR
000-0028439-18

HRV - RCV - HRV
3800

MWST - TVA - BTW
BE-402.319.970/090.092